

---

Alliances in Industrial Purchasing: The Determinants of Joint Action in Buyer-Supplier Relationships

Author(s): Jan B. Heide and George John

Source: *Journal of Marketing Research*, Feb., 1990, Vol. 27, No. 1 (Feb., 1990), pp. 24-36

Published by: Sage Publications, Inc. on behalf of American Marketing Association

Stable URL: <https://www.jstor.org/stable/3172548>

---

JSTOR is a not-for-profit service that helps scholars, researchers, and students discover, use, and build upon a wide range of content in a trusted digital archive. We use information technology and tools to increase productivity and facilitate new forms of scholarship. For more information about JSTOR, please contact [support@jstor.org](mailto:support@jstor.org).

Your use of the JSTOR archive indicates your acceptance of the Terms & Conditions of Use, available at <https://about.jstor.org/terms>



American Marketing Association and Sage Publications, Inc. are collaborating with JSTOR to digitize, preserve and extend access to *Journal of Marketing Research*

JSTOR

Recent trends in industrial markets indicate that buyers and sellers are increasingly supplanting conventional "arm's length" arrangements with "alliances" involving closer ties. The authors develop a theoretical model of industrial buyer-supplier ties that presents joint action as a key aspect of closeness. Whereas conventional ties emphasize a clearly defined division of labor, these newer relationships are distinguished by more tightly integrated roles based on undertaking activities jointly. Drawing primarily on a normative theory of transaction costs, the authors identify the conditions under which these relationships are useful. The utility of the relationships derives from an ability to safeguard relationship-specific investments and to facilitate adaptation to uncertainty. Using data from a sample of industrial firms and their suppliers, the authors test these predictions. The results show good support for the model. Consequences for research and practice in marketing are drawn.

## Alliances in Industrial Purchasing: The Determinants of Joint Action in Buyer-Supplier Relationships

During the last few years, the nature of buyer-supplier relationships has been undergoing some dramatic changes. Industry observers describe these ties as becoming "closer" (e.g., *Business Week* 1987) and terms such as "alliances" (Spekman 1988) and "partnerships" (Johnston and Lawrence 1988) are being used to contrast them with the more traditional "arm's length" type of interaction.

Despite the seeming importance of these shifts, the literature is deficient in some important ways. There is no theoretical framework that explicates the content of these relationships. The practice-oriented literature is of little help as there is little or no acceptance of definitions of terms such as "closeness." Further, there is virtually no research evidence on the antecedents or outcomes of these shifts. Though causal empiricism and industry accounts hint that different types of relationships are useful in different circumstances, and that closeness does not always work (Harrigan 1985), the lack of theory-based investigations leaves one unable to begin to assess their

potential properly. This weakness is critical given the nontrivial level of risk and resources potentially involved in setting up purchasing arrangements.

We describe a model of original equipment manufacturer (OEM)-supplier ties that identifies specific dimensions of these relationships. It enables us to describe in operational terms the shifts away from traditional arm's length purchasing arrangements. We draw on a normative transaction cost analysis (TCA) approach supplemented with descriptive theories from organizational research. We identify the antecedents of these shifts and test our research propositions in an empirical study. Finally, we offer some thoughts on the consequences of our work for research and practice in marketing. The normative emphasis of transaction cost analysis is particularly helpful in providing insight into the circumstances that warrant developing closer ties with suppliers.

### *DIMENSIONS OF INDUSTRIAL BUYER-SUPPLIER RELATIONSHIPS*

At a basic level, our theoretical argument is that the establishment of a closer relationship corresponds to a shift away from *market-based exchange* toward more *bilateral governance* (Williamson 1985). Unfortunately,

---

\*Jan B. Heide is Assistant Professor of Marketing, Weatherhead School of Management, Case Western Reserve University. George John is Associate Professor of Marketing, Carlson School of Management, University of Minnesota.

Williamson does not identify operational dimensions of governance structures. Researchers readily accept the notion that governance is a multidimensional phenomenon (e.g., Dwyer, Schurr, and Oh 1987), but there is little consensus as to the dimensions that characterize the construct.

Given the diversity of arrangements between firms, it appears virtually impossible to construct a theoretically meaningful definition of closeness in a context-free sense that would generate an exhaustive list of operational dimensions. A more promising approach to the problem is to propose a middle-range extension (Merton 1957) to the basic theoretical framework of TCA. Hence we limit our study to a subset of interfirm relationships and rely on certain features of the context to extend Williamson's general theoretical argument. We use Harrigan's (1985) distinction between interfirm relationships that are based on joint equity participation and those that do not involve pooling of equity interests. We do not consider joint ventures between firms and their suppliers of components. Likewise, royalty-based technology transfers between OEMs and suppliers are outside the scope of our model. We examine only those purchasing arrangements between firms and their suppliers in which the financial independence of each party is maintained.

In our model, purchasing relationships differ on three dimensions: joint action, expected continuity, and verification efforts. Though they clearly do not exhaust the possible differences across arrangements, these dimensions are implicated by theoretical accounts of interfirm arrangements and are consistently noted by industry observers.

#### *Joint Action*

We define joint action as the degree of interpenetration of organizational boundaries (Guetzkow 1966; Laumann, Galaskiewicz, and Marsden 1978). In conventional procurement, the responsibility for a given task (e.g., product design) is assigned to one or the other party. In contrast, a move toward closer relationships involves the parties carrying out the focal activities in a cooperative or coordinated way. Organizational boundaries become penetrated by the integration of activities as the supplier becomes involved in activities that traditionally are considered the buyer's responsibility and vice versa.

Joint action in industrial purchasing relationships can occur over a large set of activities, including tool development and product design (Drozdowski 1986), value analysis and cost targeting (Dowst 1988), design of quality control and delivery systems (Treleven 1987), and long-term planning (Spekman 1988). As the extent and scope of joint activities increase, the firms effectively become partners in an alliance.

In the language of governance mechanisms, joint action implies a departure from market-based exchange as the roles of buyer and supplier are no longer narrowly defined in terms of the simple transfer of ownership of a product or service. According to Butler (1983), "the

whole man" is not required in order to carry out transactions in market exchange. This situation contrasts sharply with the more comprehensive and tightly integrated roles of buyer and supplier in a close relationship.

Interestingly, closeness has been described in a strikingly similar way in theoretical analyses of interpersonal relationships. Black (1984) describes the number and nature of links uniting two parties, with a greater degree of interpenetration or participation in the other party's life becoming evident with closer ties. At the extreme is almost total involvement of one party in the exchange partner's life, approximating Bonoma's (1976) notion of "unit action."

#### *Continuity*

We define continuity as the perception of the bilateral expectation of future interaction. Whereas conventional relationships are discrete or short-term events, based on distinct points of entry and exit, closer relationships tend to be continuous or open-ended (MacNeil 1980). Several researchers (e.g., Jackson 1985; Joskow 1987; Spekman 1988) have described continuity as a key aspect of shifts toward closer purchasing relationships. Similar to joint action, this dimension is implicated also in the research on interpersonal ties. For instance, Kelley et al. (1983) stress long-run durability as an important aspect of closer ties.

The definition involves anticipated duration into the future rather than the historical duration to date. This distinction is important and is discussed further in developing the hypotheses. Also, it is not the attitude or one party's desire to continue the exchange that matters; rather, it is the perception of a bilateral expectation of continued exchange.

#### *Verification of Supplier*

Verification is defined as the scope of efforts undertaken by the buyer *ex ante* to verify the supplier's ability to perform as expected. In industry parlance, it often is referred to as supplier qualification. Verification is distinct from inspection upon delivery and it ranges from perfunctory credit checks to examining a supplier's manufacturing operations, production capacity, personnel, and technological capabilities (Leenders and Blenkhorn 1988).

Whereas conventional relationships generally are unaffected by the identity of a particular exchange partner, establishing more bilaterally governed ties requires a more stringent screening of the other party. Accounts of more exhaustive supplier evaluation by firms crafting closer ties are readily found in the trade press (e.g., *Business Week* 1987). For instance, the completion of a formal qualification program has been made a prerequisite for involving suppliers in such activities as product design and concept testing (Drozdowski 1986).

Verification efforts in close interfirm relationships have parallels in models of close interpersonal relationships. According to Levinger (1980), establishing a close re-

relationship begins with *awareness* and *build-up* stages, wherein the parties learn about "the other's probable behavior" (Levinger 1980, p. 529).

Note that we limit our study to the verification efforts undertaken by buyers. The buyers in our study are original equipment manufacturers (OEMs). As it happens, only the OEM undertakes such efforts in industrial purchasing. The middle-range scope of the model is evident here, as we define a variable that pertains to only one side of the dyad. In principle, verification efforts could be undertaken by both parties, but in a middle-range formulation we remain as faithful as possible to the context at hand.

### MODEL

We have described three key dimensions along which OEM-supplier relations change as they become closer (or shift toward more bilateral governance). On the basis of TCA reasoning, *specific assets* and *uncertainty* are the principal factors that evoke shifts toward more bilateral governance. Our hypothesized relationships are summarized in Figure 1.

The following discussion centers on the outcome variables (expectations of continuity, verification efforts, and joint action) as viewed by the OEM. Hence the model is not dyadic. However, certain of the variables are present at the firm level as well as at the dyadic level, and hence make for a mixed-level model (Rousseau 1985). This fact has implications for measure validation and is discussed subsequently. Our description of the model begins with the links between the three dimensions de-

scribed previously. Then we describe the links between the explanatory variables and these outcome variables.

### Continuity and Verification Effects on Joint Action

**Continuity.** Stronger expectations of continued exchange support higher levels of joint action for several reasons. First, the short-run inequities that arise are corrected more readily when the parties expect to continue to interact into the future (Kelley and Thibaut 1978). Further, when the association is perceived to be more durable, each party is more confident that the other will perform its activities faithfully because "the shadow of the future" has been enlarged (Axelrod 1984). Essentially, future interaction between exchange partners provides an opportunity to reward good behavior and punish opportunism. In our context, joint action leaves a firm potentially vulnerable to erratic role performance by the other party, which can be managed by expanding the anticipated time horizon of the exchange.

Notice that the reasoning is based on the expected duration of the exchange, rather than on the historical duration of the relationship. Though expectations of continuity may be induced by past association, the key issue is whether the parties expect to continue the exchange (Axelrod 1984). We can summarize this argument as:

H<sub>1</sub>: Greater continuity expectations increase the level of joint action.<sup>1</sup>

**Verification.** Like continuity, greater supplier verification supports more joint action. Higher levels of joint action introduce more uncertainty into a firm's decision-making because its activities are directly influenced by the other party's role performance and the firm must concede some greater degree of organizational autonomy (Pfeffer and Salancik 1978). It is the perceived risk associated with these consequences that is reduced by undertaking verification efforts. More screening enables a firm to ascertain better the motivation and capability of the other party. Notice that such verification may be undertaken in an ongoing relationship, but it is an *ex ante* action that is different from verifying delivered performance *ex post*. *Ex post* verification consists of such activities as inspection upon delivery. We can summarize this argument as:

H<sub>2</sub>: Increased verification efforts by the buyer increase the level of joint action.<sup>2</sup>

We see that continuity and verification support greater levels of joint action, but why is joint action necessary in the first place? We turn to this matter next by ex-

Figure 1  
RELATIONSHIPS IN MODEL

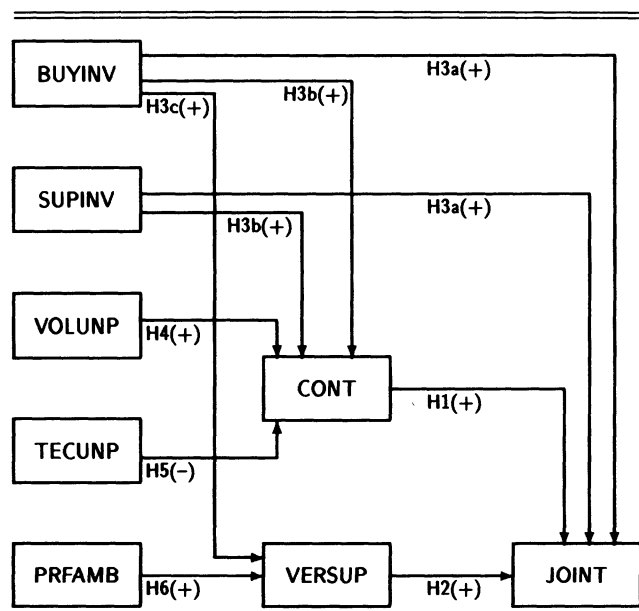

<sup>1</sup>Might successful joint action induce expectations of continuity? Possibly, but a long history of previous exchange is probably a more potent predictor. As shown subsequently, this possibility is controlled for in the estimated model.

<sup>2</sup>The reverse causation issue is not plausible here. Verifying future capabilities does not reduce risks associated with current joint action.

aming the effects of each of the two principal independent constructs.

#### *Effects of Specific Investments*

Specific investments are investments made by a firm that are of considerably less value outside the focal relationship. In the OEM-supplier context, they may include tools, equipment, operating procedures, and systems that are tailored for use with specific firms. Their presence poses a problem for the investing party because their value depends on good-faith behavior or forbearance by the other party.

According to TCA, it is imprudent to assume that parties to an exchange will forgo opportunistic behavior. Consequently the investing firm needs to safeguard its specific investments from the possibility of relationship termination or "opportunistic expropriation" (Klein, Crawford, and Alchian 1978). The initial safeguard identified in the TCA literature is vertical integration. The bureaucratic control and ownership of residual profits afforded by ownership reduce the capacity and motivation of others to expropriate the value of one's specific investments. Recently, additional safeguards have been proposed, including hostages (Williamson 1985) and offsetting investments (Heide and John 1988). Importantly, both of these latter safeguards can be put in place in relationships between independent firms.

We propose that joint action serves as a safeguard for specific investments in our context. Our reasoning is that bilateral governance in the form of joint action helps to curb opportunistic tendencies that might erode the value of specific investments. It is the shared operational control over assets implied by joint action that serves this function. As Leenders and Blenkhorn (1988) describe it, firms that make investments in a relationship with a supplier will want to get involved in activities that traditionally are considered the other party's exclusive domain in order to minimize the risks involved. For instance, manufacturers may involve suppliers to a greater degree in the product design process to maximize the value of present tools and equipment. In this way, the risk of tool obsolescence due to unilateral design changes is lowered.

Palay's (1984) study of rail shippers and carriers provides empirical support for this notion. He found that more joint planning was undertaken as a safeguard against opportunistic abuse of the shipper-specific investments made by the rail carriers. In a related argument, Kogut (1988) has suggested that joint ventures (an extreme form of joint action) are a response to the presence of specific assets.

The basic argument is complicated to some extent by two distinct sources of specific assets in our context. In an OEM-supplier relationship, each of the parties may have invested in specific assets. We propose that the effects are additive, wherein both OEM and supplier investments in specific assets increase the level of joint action.

One might argue instead that specific assets from each side interact to attenuate the need for safeguards like joint action. Symmetric exposure from such investments constitutes a safeguard in the form of mutual hostages. We argue against such a possibility because specific assets do not have the characteristics of "good" hostages, which are valued more highly by the giver than the taker (the traditional ugly princess fits this requirement). Nevertheless, we test for the presence of such an interactive effect.

H<sub>3a</sub>: Specific investments made by OEMs and suppliers will increase the level of joint action.<sup>3</sup>

Specific investments have indirect effects on joint action as well. The switching costs imposed by specific assets make short-term exchange hazardous (Treleven 1987). As Joskow (1987) has demonstrated, one safeguard is a more durable, longer lasting relationship. Such durability may arise from explicit contractual terms or a bilateral expectation of continuity.

A related line of reasoning used by Axelrod (1984) is that the expectation of future exchange by the parties constitutes a credible capacity for retaliation if opportunism occurs. This restraint on opportunistic inclinations provides a safeguard for specific investments. As we discussed before, such expectations in turn support more joint action.

H<sub>3b</sub>: Specific investments made by OEMs and suppliers increase expectations of continuity.

The other indirect effect of specific assets on joint action is mediated by supplier verification efforts. Because specific investments by an OEM leave the firm exposed to opportunistic behavior, it has an incentive to verify the capabilities of the supplier before establishing a relationship. Recall that these supplier verification efforts in turn support higher levels of joint action. Hence, specific assets affect joint action through this variable as well. Notice that the sequence of events involves only the specific investments of the buyer. As we noted before, in the context of the middle-range model, only OEMs undertake verification efforts. Hence, this safeguard applies only to them.

H<sub>3c</sub>: Specific investments made by OEMs increase their supplier verification efforts.

#### *Effects of Uncertainty*

At a basic level, uncertainty creates adaptation and information processing problems for a firm (Aldrich 1979). Though the uncertainty construct appears prominently in many theoretical models, conflicting claims appear about its effects. In his review, Scott (1987) notes that uncer-

<sup>3</sup>It is plausible to argue the reverse sequence of events—that specific investments will be made only in relationships that already have safeguards. Our cross-sectional data do not allow us to rule out this possibility.

tainty has been found to imply both tight and loose coupling between decision-making units. Recently, Balakrishnan and Wernerfelt (1986) have argued that these conflicting claims are due to rather distinct aspects of uncertainty that have been confounded previously in broad definitions of the construct. We isolate three different forms of uncertainty—volume unpredictability, technological unpredictability, and performance ambiguity—and analyze the effect of each individually.

*Volume unpredictability.* We define volume unpredictability as the inability to forecast accurately the volume requirements in the relationship (Walker and Weber 1984). In our context, the volatility of the downstream market and the manufacturer's share of this market both contribute to unpredictability, which in turn requires a firm to develop mechanisms for adaptation. One approach to adaptation is to design procedures for sequential decision making within the context of an ongoing relationship, thereby economizing on the difficulty of making changes (Williamson 1985).

We posit that adaptation to changes is carried out more readily when there are stronger expectations of relationship continuity. In Axelrod's (1984) terms, enlarging the shadow of the future makes it easier for parties to cooperate and to cope with unanticipated changes. Why is this so? One way to understand this effect is to specify what it means to cooperate in order to adapt. An essential feature of cooperation in the face of unanticipated change is the need to forgo taking short-term advantage of the situation to one party's unilateral benefit. Such forbearance is easier to practice when the firm is more certain that bilateral expectations of continuity provide it the capacity to retaliate against opportunism and to reciprocate forbearance. Hence:

H<sub>4</sub>: Perceptions of volume unpredictability increase expectations of continuity.

*Technological unpredictability.* We define technological unpredictability as the inability to forecast accurately the technical requirements in the relationship (Walker and Weber 1984). It may follow from changes in the standards or specifications of the components or end product, or from general technological developments. Though technological unpredictability requires a firm to find means of coping with it, its effect on adaptation is opposite that of volume unpredictability.

Unlike volume unpredictability, which motivates tighter interfirm linkages to facilitate adaptation, technological unpredictability is managed more efficiently through loose coupling or lower continuity. By not establishing long-lasting linkages in the presence of technological unpredictability, firms retain the flexibility to terminate relationships and switch to partners with more appropriate technological capabilities (Balakrishnan and Wernerfelt 1986).

H<sub>5</sub>: Perceptions of technological unpredictability reduce expectations of continuity.

*Performance ambiguity.* We define performance ambiguity as the difficulty of accurately measuring *ex post* the exchange partner's compliance with expected output (Williamson 1985). To the degree that such *internal uncertainty* is present, a firm is exposed to the risks of opportunistic exploitation. In our context, the observability of component quality and production processes is at the core of internal uncertainty.

Performance ambiguity motivates a firm to find means of reducing the risks of opportunism. As Ouchi (1980) has argued persuasively, high levels of performance ambiguity require that output-based measures be supplemented with other control mechanisms. On the basis of this reasoning, we posit that supplier verification efforts increase in the face of performance ambiguity. Simple *ex post* inspection of the delivered items is unlikely to be sufficient. Verification efforts address uncertainty proactively by imposing selective entry requirements on the relationship through the selection of exchange partners that meet predetermined criteria.

H<sub>6</sub>: Perceptions of performance ambiguity increase supplier verification efforts.

### *Effects of Other Variables*

In addition to the preceding variables, certain other measures are included in our study. They represent potentially influential variables outside the focal theory that might nevertheless play an important role in our setting of OEM-supplier relations. By accounting for these other effects, we strengthen the tests of the focal relationships. Three sets of such variables are included.

*Importance of relationship.* Leenders and Blenkhorn (1988) argue that because joint action involves high setup costs, it is more likely to occur in more important relationships as reflected by the size of purchases or by the criticality of the purchased item (Spekman 1988). Relationship importance probably also increases continuity expectations. Presumably, firms would be reluctant to switch important sources often. Finally, we would also expect firms to make more strenuous efforts to verify suppliers' capabilities in more important relationships simply because more is at stake.

*Manufacturing process.* The buying firm's manufacturing process may impose certain requirements on its supplier relationships (Hakansson 1982). For instance, relatively more automated processes such as assembly-line operations have lower tolerances for instability than small-batch or job-shop operations. Hence, longer run relations are more likely to be found for more automated processes. We include a measure of the automaticity of the buyer's manufacturing process as a determinant of continuity expectations.

*History effects.* The age or historical length of the relationship is included because parties that have managed to align their interests effectively over time are more likely to expect continued future exchange.

## METHOD

### Research Setting

The research setting chosen for the study comprised OEMs in three two-digit SIC major groups (35, 36, and 37) involved with purchasing subassemblies and/or components from suppliers. Firms in these three groups manufacture machinery (except electrical), electrical and electronic machinery, and transportation equipment, respectively. These groups were chosen in order to capture a sufficient variety of purchasing relationships to test our theoretical model. Note that each two-digit major group contains dozens of four-digit industries. This sample restriction reduces the extraneous sources of variation that might mask effects within a middle-range model. It also assists in developing grounded measures.

### Pilot Study and Measure Development

The first phase of the fieldwork consisted of attending an industry conference on supplier ties, where it was evident that the issues we examine were of substantial interest to firms in the research setting. Some of the attendees were contacted subsequently for followup field visits to their plant sites. These site visits yielded personal interviews with both industrial buyers and suppliers. From these exploratory investigations we found that there is substantial variation in buyer-supplier ties and that the constructs in our theoretical model could be measured in the OEM-supplier context.

A draft of the questionnaire was developed and personally administered at four different OEM sites. Subsequently a revised questionnaire was developed and administered by mail to a sample of 25 OEMs in the designated SIC major groups. This mail pretest revealed no major problems with any of the measures or the response format.

Two major lessons were learned from the small-sample study. First, we found that the specific investments scale could be simplified. Initially, we had included three subscales consisting of investments in plant, people, and procedures. The data suggested that a single dimension sufficed to capture the variation. The final questionnaire reflected this change. Second, we found nonuniform distribution of knowledge among potential informants. Typically, one good informant could be identified. Finding a second informant was generally very difficult because their knowledge base was quite narrow (engineering, purchasing, etc.), thus precluding a multiple-informant strategy. Table 1 shows sample items from the final questionnaire and the response formats.

### Measures

*Specific investments of buyer (OEM).* The BUYINV scale describes the investments made by the OEM in physical assets, procedures, and people that are tailored to the relationship with a particular supplier. It is based on the items developed by Anderson (1985).

*Specific investments of supplier.* This scale (SUPINV) is similar in format to the preceding one, but it describes the investments made by the supplier in the relationship with a particular OEM.

*Volume unpredictability.* The VOLUNP scale describes the inability to forecast accurately the demand for the components in question. It is based on the scale used by Walker and Weber (1984).

*Technological unpredictability.* The TECUNP scale, similar in format to the preceding one, describes the inability to forecast accurately the technological requirements in the relationship.

*Performance ambiguity.* This scale (PRFAMB) describes the difficulty faced by the buyer (OEM) in evaluating the supplier's performance *ex post* by inspection or other such means.

*Expectations of continuity.* The CONT scale describes the perception of the firm that both parties expect the relationship to continue into the future. Note that it does not measure the time left in the formal contract (if one exists).

*Verification of supplier.* The VERSUP scale describes the extent to which the OEM undertakes efforts to verify the capabilities of the supplier. To develop this scale, we first itemized the domain into a set of relevant activities. Then each activity was assessed on a 7-point format. This procedure of itemizing the domain creates a formative scale rather than a reflective scale. The construct is defined as the sum of the items, rather than giving rise to each item as is the model in the more common reflective scales (Bagozzi and Fornell 1982). This approach has implications for reliability assessment, which we address subsequently.

*Joint action.* This scale (JOINT) describes the extent to which the parties undertake activities jointly rather than unilaterally. Again, we first itemized the domain of activities and each activity was assessed on a 7-point format. The itemization of the domain leads to a formative scale.

*Importance of relationship.* The measures of relationship importance are (1) the logarithm of the annual dollar purchases (\$AMOUNT) from the focal supplier,<sup>4</sup> (2) the percentage value of the end product accounted for by the component in question (%VALUE), and (3) the impact of the component quality on the end product (IMPACT), measured on a 7-point scale.

*Other measures* include a measure of the manufacturing process used by the buyer (MANUF), based on the scale developed by Hickson, Pugh, and Phesey (1969), and the historical length of the relationship (LENGTH), measured by the time period over which the buyer has been purchasing from the supplier.

<sup>4</sup>The logarithm of the dollar amount was used to reflect diminishing returns to size.

**Table 1**  
**QUESTIONNAIRE RESPONSE FORMATS AND SAMPLE ITEMS**

<i>Scale</i>	<i>Response anchors</i>	<i>Sample items</i>
Buyer's specific investments (BUYINV)	Likert 7-point scale, "strongly disagree/strongly agree"	We have made significant investments in tooling and equipment dedicated to our relationship with this supplier. Our production system has been tailored to using the particular items bought from this supplier.
Supplier's specific investments (SUPINV)	Same as above	The procedures and routines developed by this supplier as part of their relationship with our company are tailored to our particular situation. Our company has some unusual technological standards and norms that have required extensive adaptation by the supplier.
Volume unpredictability (VOLUNP)	Likert 7-point scale, "unpredictable/predictable"	Industry sales volumes for end product. Your company's sales volume for end product.
Technological unpredictability (TECUNP)	Same as above	Technological changes in the end product. General technological developments in the supply market for the components bought.
Performance ambiguity (PRFAMB)	Likert 7-point scale, "strongly disagree/strongly agree"	It is inadequate to evaluate this supplier based only on component prices. Conducting performance evaluations of this supplier requires making sure they follow the approved production and quality control procedures.
Expectations of continuity (CONT)	Likert 7-point scale, "strongly disagree/strongly agree"	The parties expect this relationship to last a long time. The parties make plans not only for the terms of the individual purchase, but also for the continuance of the relationship.
Supplier verification (VERSUP)	Likert 7-point scale, "minimal evaluation of supplier/ extensive evaluation of supplier"	Engineering capability. Manufacturing capability. Personnel/management resources.
Joint action (JOINT)	Likert 7-point scale, "minimal joint effort/extensive joint effort"	Component testing/prototyping. Long-range planning. Forecasting component requirements.

### *Data Collection*

Our sampling frame consisted of a mailing list of purchasing agents/directors obtained from Dun and Bradstreet consisting of manufacturing firms in two-digit SIC major groups 35, 36, and 37. A random sample of 1157 names was drawn from the sampling frame. The individuals were contacted by phone to solicit participation in the study and identify the relevant key informants.

*Informant selection and response rates.* Using key informants for data collection involves administering the questionnaire to selected individuals within the sampled firms who have particular knowledge about the phenomena under study. The presurvey phone contact enabled us to find 579 informants (50% of the 1157) who met the knowledgeability criteria for key informants and also agreed verbally to complete the survey. For 20% of the 1157 names the firm could not be located and for another 13% an appropriate key informant could not be found within the time constraints imposed by the administration of the survey. Another 8% refused to participate and 9% were judged inappropriate for inclusion in the study because they either purchased items for direct resale or purchased from a supplier that was simply a component distributor rather than a manufacturer.

Each informant completed the survey instrument with reference to a self-selected supplier about whom he was

knowledgeable. Callbacks and a second mailing yielded 175 questionnaires (30% of 579 mailed). Presumably, the very extensive nature of the questionnaire precluded a higher return rate.

As a final check on our informant selection, each questionnaire contained self-report scales on the informant's degree of knowledge of and involvement in the firm's supplier relations. After elimination of 20 questionnaires that indicated insufficient levels of knowledge and involvement and/or on which excessive amounts of data were missing, the final sample consisted of 155 buying firms. These firms purchase a variety of components, including fabricated metal parts, electronic sub-assemblies, and finished components such as motors and power units.

*Nonresponse bias.* Nonresponse bias was assessed by comparing early with late respondents as suggested by Armstrong and Overton (1977). We received 77% of the questionnaires well before the last 23% and formed two groups based on this criterion. The groups were compared by using *t*-tests. No significant differences were found on a number of variables such as sales volume, number of employees, and value of purchases. Nonresponse bias does not appear to be a significant issue, though a stronger test would have been to contact non-respondents.

*Construct Validity*

The first step in the construct validation process, an assessment of internal consistency and unidimensionality, requires consideration of the nature of the scales employed. Recall that two of the scales (JOINT and VERSUP) were developed by itemizing the construct domain to provide formative scales whereas the remainder of the multi-item scales are reflective measures. Because different models underlie the two types, the assessment procedures also differ.

*Internal consistency of reflective scales.* For each of the reflective scales, we began by using item-to-total correlations to identify ill-fitting items. Then the remaining items were subjected to a confirmatory factor analysis using LISREL VI (Jöreskog and Sörbom 1985). A single-factor representation was used for each set of congeneric items. The fit statistics associated with these models are reported in Table 2. The chi square statistics are significant and the other fit indices show an adequate fit to the data. After the acceptance of an adequate LISREL model for each item set, its reliability was calculated. These estimates (Table 2) are all above the traditional benchmark with the exception of the technological unpredictability scale (TECUNP), which has a borderline estimate of .58.

*Internal consistency of formative scales.* A Rasch latent trait model was estimated for each of the two formative scales (JOINT and VERSUP) as it is more consistent with a formative scale. Briefly, the Rasch model assumes that the response to a rating scale item *i* is a function of the amount of trait  $\beta_j$  present in firm *j* and

a parameter  $\delta_i$  that describes the amount of the trait present in item *i*. Thus, firms having a large amount of the trait would respond favorably to more items. Cohen (1979) provides a fit statistic, *C*, for such models as well as an analog to Cronbach's internal consistency estimate.

Using SYSTAT (Wilkinson 1986), we obtained estimates of these parameters and the statistics associated with the items. The joint action scale (JOINT) shows sufficient fit to the data (*C* = .07, which is close to the zero benchmark) and its Cohen internal consistency coefficient appears adequate at .70. The VERSUP scale also shows adequate fit to the data (*C* = .03) and the internal consistency estimate of .67 is above the suggested benchmark of .60.

*Convergence within firms.* Care was taken to ensure that the informants in our sample of buying firms were selected properly. However, because their knowledge and involvement were assessed via self-reports, additional evidence about their agreement with other sources would be desirable. In particular, some researchers have questioned the ability of key informants to report validly (e.g., Phillips 1981), though others (e.g., John and Reve 1982) have shown that applying Campbell's (1955) criteria for selecting informants can provide valid informant reports.

We therefore investigated the quality of the informant reports in more detail. An effort was made to obtain a report from a second informant in each firm. Callbacks were made to the first informant with the objective of identifying a second person in the firm who was in a position to describe the supplier relationship in question. Of the 155 informants contacted, only 45 identified a second informant in their firm. This person then was contacted and asked to complete a questionnaire. Callbacks and elimination of persons who failed to meet the established criteria for informant involvement and knowledge yielded 21 second informants.

Though this sample is too small to use in statistical analysis, it is interesting to note that our contact with the informants revealed that this problem is due to the pattern of organizational roles. Typically, the firms in the sample establish one person as the focal point for relations with a given supplier. Almost everyone else is involved only on a partial basis. For instance, product design decisions with suppliers would involve design engineers, but they would know little about the quality control procedures being used. In effect, the distribution of knowledge in this context renders an intrafirm multiple-informant validation strategy virtually infeasible. Recall that this was the case in the initial pretest as well.

*Convergence across firms.* Another step undertaken to assess the quality of the measures obtained in the OEM sample involved obtaining data from the focal suppliers. Recall that each OEM informant provided data about the relationship with a particular supplier. We asked each of these informants to identify a person in the supplier's firm who would be knowledgeable about the focal relationship. From the 155 OEM firms contacted, 96 names of supplier personnel were provided; these individuals

**Table 2**  
INTERNAL CONSISTENCY OF SCALES

Scale	No. of items	Fit indices	$\alpha$
BUYINV	6	$\chi^2(9) = 29.33$ $p = .001$ GFI = .94 RMSR = .06	.81
SUPINV	5	$\chi^2(5) = 17.14$ $p = .004$ GFI = .96 RMSR = .03	.90
VOLUNP	3	— <sup>a</sup>	.72
TECUNP	3	— <sup>a</sup>	.58
PRFAMB	4	$\chi(2) = 3.42$ $p = .18$ GFI = .99 RMSR = .03	.66
CONT	4	$\chi^2(2) = 17.23$ $p = .00$ GFI = .95 RMSR = .04	.88
VERSUP	8	$C = .03^b$	.67 (Cohen's index)
JOINT	9	$C = .07^b$	.70 (Cohen's index)

<sup>a</sup>Trivial fit for 3-item scale.

<sup>b</sup>Fit index for formative scales from Rasch latent trait model.

were contacted to verify their ability and willingness to provide the data. Sixty-one supplier questionnaires were returned and only one was eliminated on the basis of the self-report informant assessment.

The proper use of these data to validate the buyer data warrants discussion. The fact that exchange partners may have different perspectives on their relationships is well documented in symbolic interactionist theory (Pondy and Boje 1980). There is good reason to believe that these different perspectives are due in part to strategic posturing and use of information. As Dill (1962) notes, “. . . it is not the supplier or customer himself that counts, but the information that he makes accessible [to the partner]. . . .”

In measurement terms, these “viewpoints” mean that a congeneric model does not hold for these data. Hence any multitrait-multimethod (MTMM) analysis of the data must account for viewpoint variance<sup>5</sup> as well as trait and error variance because the measures are noncongeneric. However, our sample (60 dyads) is too small to estimate such a measurement model with LISREL; we are restricted to assessing the correlation between firms for each of the measures.

The presence of viewpoint variance serves to attenuate the raw correlations, so care must be taken in interpreting them. Looking at Table 3, we note that despite the attenuation due to the viewpoint factors, all but two of the measures correlate significantly with each other across the dyad. Hence, our OEM informant reports appear to be of adequate quality.

Interestingly, both of the insignificant correlations pertain to uncertainty. Previous work in organizational theory has shown that uncertainty is an extremely elusive construct (Scott 1987) and some theorists (e.g. Weick 1969) have argued that perceptions of uncertainty are purely idiosyncratic because the environment is “enacted” by the perceiver. Consequently, they should not converge across dyads. This issue is expanded upon in the Discussion section.

**Discriminant validation.** Using the data from the OEM sample, we assessed the discriminant validity of the six reflective measures by estimating a six-factor measurement model using LISREL VI. Each item was set to load only on its own trait, and the traits were allowed to correlate. Though the overall chi square statistic is significant ( $\chi^2(260) = 431.85, p = .00$ ), the various fit indices show a reasonable fit (GFI = .82, RMSR = .07, Bentler and Bonett's  $\Delta = .77, \rho = .87$ ).

Given the model, discriminant validity then was examined for each pair of traits by constraining the relevant intertrait correlation to unity and estimating this new model. Then the difference in chi square values between the two models was tested. A significant chi square dif-

Table 3  
CORRELATIONS AMONG INFORMANT REPORTS  
ACROSS DYADS

Buyer's specific investments (BUYINV)	.33*
Supplier's specific investments (SUPINV)	.37*
Volume unpredictability (VOLUNP)	.12
Technological unpredictability (TECUNP)	.07
Performance ambiguity (PRFAMB)	.25*
Continuity expectations (CONT)	.35*
Verification efforts (VERSUP)	Not measured from suppliers
Joint action (JOINT)	.40*

\*Significant at  $p \leq .05$ .

ference would indicate that the pair of traits are not collinear, which is evidence of their discriminability. For instance, the test of discrimination between volume and technological unpredictability, which is one of the most stringent ones in the set given the similarity between these constructs, provided  $\chi^2(1) = 27.08 (p < .001)$ .

#### TESTS OF HYPOTHESES

Though the model in Figure 1 appears suited to estimation by LISREL, such a procedure would not be appropriate in this case because the measurement models in LISREL assume reflective scales. Two of our key constructs (JOINT, VERSUP) are measured with formative operationalizations that cannot be accommodated by a LISREL model.

The model consists of a set of recursive equations and therefore can be estimated well by using ordinary least squares (OLS) procedures. The coefficients were estimated with the OEM sample. The estimated standardized parameters are shown in Table 4 along with the  $t$ -statistics and levels of significance. The correlation matrix is shown in Table 5. The findings from the tests of hypotheses follow.

- H<sub>1</sub>: As predicted, continuity expectations have a significant positive effect on the levels of joint action ( $b = .104$ ).
- H<sub>2</sub>: As predicted, verification efforts significantly increase the levels of joint action ( $b = .267$ ).
- H<sub>3a</sub>: As predicted, both OEM's specific investments ( $b = .299$ ) and suppliers' specific investments ( $b = .273$ ) significantly increase the extent of joint action in the relationship.<sup>6</sup>
- H<sub>3b</sub>: As predicted, suppliers' investments in specific assets significantly increase the expectations of continuity ( $b = .248$ ). However, OEM's investments in specific assets do not show a significant effect on continuity.
- H<sub>3c</sub>: As predicted, specific investments made by OEMs

<sup>5</sup>We prefer the term “viewpoint” over “method” variance because the sources of variation are attributable not to measurement artifacts, but to systematic perceptual differences between buyers and suppliers.

<sup>6</sup>An additional model was run to assess the possibility of a negative interaction coefficient. Recall this was the alternative view for symmetric levels of specific investments. No significant interaction was found.

**Table 4**  
ESTIMATED MODEL

Independent variables	Dependent variables		
	CONT	Standardized coefficients (t-values) VERSUP	JOINT
CONSTANT	.000 (4.56) <sup>a</sup>	.000 (.44)	.000 (-1.84) <sup>b</sup>
BUYINV	.003 (.037)	.143 (1.65) <sup>a</sup>	.299 (4.36) <sup>a</sup>
SUPINV	.248 (2.63) <sup>a</sup>	—	.273 (3.69) <sup>a</sup>
VOLUNP	.062 (.65)	—	—
TECUNP	-.283 (-3.20) <sup>a</sup>	—	—
PRFAMB	—	.150 (1.76) <sup>a</sup>	—
CONT	—	—	.104 (1.51) <sup>b</sup>
VERSUP	—	—	.267 (3.68) <sup>a</sup>
%VALUE	.113 (1.42) <sup>b</sup>	.174 (2.18) <sup>a</sup>	.082 (1.34) <sup>b</sup>
IMPACT	.111 (1.37) <sup>b</sup>	.102 (1.27)	.044 (.72)
\$AMOUNT	.086 (1.01)	.170 (2.09) <sup>a</sup>	.083 (1.29)
MANUF	-.018 (-.20)	—	.006 (.10)
LENGTH	.118 (1.43) <sup>b</sup>	—	-.031 (-.50)
<i>R</i> <sub>adj</sub> <sup>2</sup>	.15	.15	.52
<i>F</i> ( <i>n</i> , <i>m</i> )	(9,129) = 3.64 <sup>a</sup>	(5,134) = 5.70 <sup>a</sup>	(9,128) = 17.5 <sup>a</sup>

<sup>a</sup>Significant at  $p \leq .05$  (1-tailed test).

<sup>b</sup>Significant at  $p \leq .10$  (1-tailed test).

lead to significantly higher levels of verification efforts ( $b = .143$ ).

H<sub>4</sub>: The expected positive effect of volume unpredictability on continuity is not found.

H<sub>5</sub>: As predicted, technological unpredictability decreases the expectations of continuity ( $b = -.283$ ).

H<sub>6</sub>: As predicted, performance ambiguity increases the level of verification efforts ( $b = .150$ ).

The effects of the control variables give some interesting results. Table 4 shows that as the value of the component as a percentage of the end product (VALUE) increases, continuity increases ( $b = .113$ ), as do verification efforts ( $b = .174$ ) and joint action ( $b = .082$ ). Presumably, closer relationships are more likely to occur when relatively more critical components are involved.

The dollar volume of components purchased significantly increases the verification efforts undertaken by the OEMs ( $b = .170$ ), but has no effect on continuity or joint action. Note, however, that it has an indirect effect on joint action through the effect on verification.

As expected, the historical length of the relationship significantly increases the continuity expectations ( $b = .118$ ). Finally, the nature of the manufacturing process has no effect on any of the dependent variables.

**DISCUSSION**

The main purpose of our research is to develop a model of closeness in industrial buyer-supplier relationships and to test empirically the relationships between the dimensions of closeness and their antecedent conditions. The aspects of relationship closeness examined are joint action, continuity expectations, and verification efforts. Our general hypothesis is that close relationships emerge as responses to the need for safeguarding transaction-specific assets and adapting to uncertainty. Overall, the estimated models show relatively good support for our hypotheses involving the effects of transaction-specific assets on close relationships. All of the hypotheses involving specific assets are supported, with the exception of the effect of OEMs' investments on continuity. For the ef-

**Table 5**  
CORRELATION MATRIX OF VARIABLES

	BUYINV	SUPINV	VOLUNP	TECUNP	PRFAMB	CONT	VERSUP
BUYINV	1.0						
SUPINV	.45	1.0					
VOLUNP	-.19	-.22	1.0				
TECUNP	.05	-.10	.44	1.0			
PRFAMB	.37	.32	-.17	-.03	1.0		
CONT	.15	.28	-.12	-.28	.13	1.0	
VERSUP	.26	.36	-.16	-.09	.25	.46	1.0
JOINT	.54	.57	-.23	-.08	.33	.38	.54

$r > .16$  are significant at  $p \leq .05$  for  $n = 155$

facts of uncertainty, all of our hypotheses are supported by the data with one exception. The expected positive effect of volume unpredictability on continuity expectations is not found.

### *Consequences for Research*

Our study builds on previous applications of transaction cost theory in marketing to offer a middle-range conceptualization of interfirm exchange. Traditionally, TCA has viewed the crafting of safeguards in terms of "global" strategies such as vertical integration (Anderson 1985; Walker and Weber 1984). Our results suggest that safeguards can be achieved in a more discriminating way without involving global action such as vertical integration and that different mechanisms are available that are sensitive to the specific problems at hand. Exploring other specific safeguards appears to be a fruitful avenue for future research. Of particular value would be work to identify how specific safeguards are selected from an available set.

While the development of TCA along the lines of identifying specific safeguards has been occurring, the literature has been rather deficient in assessing the normative implications of the approach. Like other researchers, we have examined only whether firms follow the prescriptions of TCA. It remains to be shown that following TCA prescriptions does indeed reduce costs (and thus enhance performance). Apart from Heide and John's (1988), no other study has tested TCA's normative aspects. Future studies should address the normative issues.

### *Consequences for Practice*

The implications of our study are viewed best within the context of practice-oriented reporting about the trends toward closer buyer-supplier ties. Almost without exception, such reporting tends to view closer relationships as a universally desirable idea. Contrast this notion with our model.

The basic postulate in our work is that bilateral governance is *not* universally desirable. It is useful only when specific assets and uncertainty evoke a need to protect and to adapt. In the absence of such needs, joint action does not have beneficial effects and, given the costs associated with shifts away from market governance, it is likely to be detrimental to performance. At the very least, our study should serve as a cautionary tale about the conditions that evoke the need to craft closer ties with suppliers.

Our findings also show that selling is not simply the "flip side" of purchasing and that different safeguards must be crafted by the various parties involved in a relationship. We find that buyers and suppliers not only have different incentives for developing close relationships, but that their approaches to developing alliances may differ. For instance, buyers can rely on verification

efforts to safeguard themselves against performance ambiguity, but this approach is not applicable to a supplier. Likewise, recall that specific investments by suppliers are found to imply greater continuity, though no effect is found for the buyer's specific assets. Possibly continuity is a more important or desirable safeguard from a supplier's than from a buyer's perspective, perhaps in the absence of other mechanisms. This asymmetry must be taken into account in practice.

### *Limitations*

The results and the implications drawn from our study should be viewed in light of the research method employed. Though the tests of the model of close relationships yield several results that are consistent with our hypotheses, the fact that a cross-sectional design was used limits our ability to rule out alternative causal inferences.

For instance, our model is based in part on the notion that close relationships emerge as a result of the need to safeguard transaction-specific assets. Though our results are generally supportive of this hypothesis, it is also conceivable that a reverse sequence of events is operating and that the existence of a close relationship *ex ante* motivates investments in specific assets or that the existence of joint action increases the expectations of continuity. Our results are consistent with the theoretical specification of events (Williamson 1985), yet alternative explanations of the results cannot be completely eliminated without longitudinal data.

Furthermore, we examine only three dimensions of buyer-supplier relationships. In particular, we do not include any measures of relational norms (Dwyer, Schurr, and Oh 1987; Kaufmann and Stern 1988; MacNeil 1980). An interesting extension of our conceptual framework would be to include such variables in the model.

Another limitation relates to the nature of the test of the model. The theoretical model of TCA is explicitly normative in that firms are presumed to craft ties that minimize transaction costs, but the test consists of assessing whether firms followed the prescriptions of TCA. It is entirely possible that firms are prompted to undertake such actions for (strategic) reasons other than efficiency. Our data do not rule out such explanations.

Finally, the lack of agreement between OEMs and suppliers on the unpredictability scales raises some interesting issues. Possibly we have failed to capture the notion of unpredictability. However, researchers in the past have measured unpredictability in a very similar way (Walker and Weber 1984), though to the best of our knowledge these scales have not been compared across buyer-supplier dyads. As pointed out in previous research (John and Reve 1982), the lack of convergence between informant reports may be related to the nature of the construct(s) involved. Enactment theories of organization-environment relations suggest that perceptions of uncertainty may be unique to individual observers (Aldrich 1979; Weick 1969), in which case consistency

across reports can hardly be expected. Obviously, more conceptual and empirical work is needed in this area.

## REFERENCES

- Aldrich, Howard E. (1979), *Organizations and Environments*. Englewood Cliffs, NJ: Prentice-Hall, Inc.
- Anderson, Erin (1985), "The Salesperson as Outside Agent or Employee: A Transaction Cost Analysis," *Marketing Science*, 4 (Summer), 234–54.
- Armstrong, J. Scott and Terry S. Overton (1977), "Estimating Nonresponse Bias in Mail Surveys," *Journal of Marketing Research*, 14 (August), 396–402.
- Axelrod, Robert (1984), *The Evolution of Cooperation*. New York: Basic Books, Inc.
- Bagozzi, Richard P. and Claes Fornell (1982), "Theoretical Concepts, Measurements, and Meaning," in *A Second Generation of Multivariate Analysis*, Vol. 2, Claes Fornell, ed. New York: Praeger Publishers, 24–38.
- Balakrishnan, Srinivasan and Birger Wernerfelt (1986), "Technical Change, Competition and Vertical Integration," *Strategic Management Journal*, 7 (July–August), 347–59.
- Black, Donald (1984), "Social Control as a Dependent Variable," in *Toward a General Theory of Social Control*, Vol. 1, Donald Black, ed. Orlando, FL: Academic Press, Inc., 1–36.
- Bonoma, Thomas V. (1976), "Conflict, Cooperation and Trust in Three Power Systems," *Behavioral Science*, 21 (November), 499–514.
- Business Week* (1987), "Closer Together" (March 30).
- Butler, Richard J. (1983), "Control Through Markets, Hierarchies and Communes: A Transactional Approach to Organizational Analysis," in *Power, Efficiency and Institutions*, Arthur Francis, Jeremy Turk, and Paul Willman, eds. London: Heinemann Educational Books, 137–58.
- Campbell, Donald T. (1955), "The Informant in Quantitative Research," *American Journal of Sociology*, 60 (January), 339–42.
- Cohen, L. (1979), "Approximate Expressions for Parameter Estimates in the Rasch Model," *British Journal of Mathematical and Statistical Psychology*, 32 (May), 113–20.
- Dill, William (1962), "The Impact of Environment on Organizational Development," in *Concepts and Issues in Administrative Behavior*, S. Mailick and E. H. Van Ness, eds. Englewood Cliffs, NJ: Prentice-Hall, Inc.
- Dowst, Somerby (1988), "Quality Suppliers: The Search Goes On," *Purchasing* (January 28), 94A4–12.
- Drozdowski, Ted E. (1986), "At BOC They Start With the Product," *Purchasing* (March 13), 62B5–11.
- Dwyer, F. Robert, Paul H. Schurr, and Sejo Oh (1987), "Developing Buyer-Seller Relationships," *Journal of Marketing*, 52 (April), 21–34.
- Guetzkow, Harold (1966), "Relations Among Organizations," in *Studies of Behavior in Organizations*, R. W. Bower, ed. Athens, GA: University of Georgia Press, 13–44.
- Hakansson, Hakan (1982), *International Marketing and Purchasing of Industrial Goods*. New York: John Wiley & Sons, Inc.
- Harrigan, Kathryn R. (1985), *Strategies for Joint Ventures*. Lexington, MA: Lexington Books.
- Heide, Jan B. and George John (1988), "The Role of Dependence Balancing in Safeguarding Transaction-Specific Assets in Conventional Channels," *Journal of Marketing*, 52 (January), 20–35.
- Hickson, David J., D. S. Pugh, and Diane C. Phesey (1969), "Operations Technology and Organization Structure: An Empirical Reappraisal," *Administrative Science Quarterly*, 14 (September), 378–97.
- Jackson, Barbara B. (1985), *Winning and Keeping Industrial Customers: The Dynamics of Customer Relationships*. Lexington, MA: Lexington Books.
- John, George and Torger Reve (1982), "The Reliability and Validity of Key Informant Data from Dyadic Relationships in Marketing Channels," *Journal of Marketing Research*, 19 (November), 517–24.
- Johnston, Russell and Paul R. Lawrence (1988), "Beyond Vertical Integration—The Rise of the Value-Adding Partnership," *Harvard Business Review*, 66 (July–August), 94–101.
- Jöreskog, Karl G. and Dag Sörbom (1985), *LISREL VI: Analysis of Linear Structural Relationships by Maximum Likelihood and Least Squares Methods*. Mooresville, IN: Scientific Software.
- Joskow, Paul L. (1987), "Contract Duration and Relationship-Specific Investments: Empirical Evidence from Coal Markets," *American Economic Review*, 77 (1), 168–85.
- Kaufmann, Patrick J. and Louis W. Stern (1988), "Relational Exchange Norms, Perceptions of Unfairness, and Retained Hostility in Commercial Litigation," *Journal of Conflict Resolution*, 32 (September), 534–52.
- Kelley, Harold H., et al. (1983), *Close Relationships*. New York: W. H. Freeman and Company.
- and J. W. Thibaut (1978), *Interpersonal Relations: A Theory of Interdependence*. New York: John Wiley & Sons, Inc.
- Klein, Benjamin, Robert G. Crawford, and Armen A. Alchian (1978), "Vertical Integration, Appropriable Rents, and the Competitive Contracting Process," *Journal of Law and Economics*, 21 (October), 297–326.
- Kogut, Bruce (1988), "A Study of the Life Cycle of Joint Ventures," in *Cooperative Strategies in International Business*, Farok J. Contractor and Peter Lorange, eds. Lexington, MA: Lexington Books, 169–85.
- Laumann, Edward O., Joseph J. Galaskiewicz, and Peter V. Marsden (1978), "Community Structure as Interorganizational Linkages," *Annual Review of Sociology*, 4, 455–84.
- Leenders, Michiel R. and David L. Blenkhorn (1988), *Reverse Marketing: The New Buyer-Supplier Relationship*. New York: The Free Press.
- Levinger, George (1980), "Toward the Analysis of Close Relationships," *Journal of Experimental Social Psychology*, 16 (November), 510–44.
- MacNeil, Ian R. (1980), *The New Social Contract*. New Haven, CT: Yale University Press.
- Merton, Robert K. (1957), *Social Theory and Social Structure*. New York: The Free Press.
- Ouchi, William G. (1980), "Markets, Bureaucracies and Clans," *Administrative Science Quarterly*, 25 (November), 129–41.
- Palay, Thomas M. (1984), "Comparative Institutional Economics: The Governance of Rail Freight Contracting," *Journal of Legal Studies*, 13 (June), 265–88.
- Pfeffer, Jeffrey and Gerald R. Salancik (1978), *The External Control of Organizations: A Resource Dependence Approach*. New York: Harper and Row Publishers, Inc.
- Phillips, Lynn W. (1981), "Assessing Measurement Error in

- Key Informant Reports: A Methodological Note on Organizational Analysis in Marketing," *Journal of Marketing Research*, 18 (November), 395-415.
- Pondy, Louis R. and David M. Boje (1980), "Bringing Mind Back In," in *Frontiers in Organization and Management*, William M. Evan, ed. New York: Praeger Publishers, 83-101.
- Rousseau, Denise M. (1985), "Issues of Level in Organizational Research: Multi-Level and Cross-Level Perspectives," in *Research in Organizational Behavior*, Vol. 7, L. L. Cummings and B. M. Staw, eds. Greenwich, CT: JAI Press, Inc., 1-37.
- Scott, W. Richard (1987), *Organizations: Rational, Natural and Open Systems*, 2nd ed. Englewood Cliffs, NJ: Prentice-Hall, Inc.
- Spekman, Robert E. (1988), "Strategic Supplier Selection: Understanding Long-Term Buyer Relationships," *Business Horizons* (July-August), 75-81.
- Treleven, Mark (1987), "Single Sourcing: A Management Tool for the Quality Supplier," *Journal of Purchasing and Materials Management*, 23 (Spring), 19-24.
- Walker, Gordon and David Weber (1984), "A Transaction Cost Approach to Make-or-Buy Decisions," *Administrative Science Quarterly*, 29 (September), 373-91.
- Weick, Karl E. (1969), *The Social Psychology of Organizing*. Reading, MA: Addison-Wesley Publishing Company.
- Wilkinson, Leland (1986), *SYSTAT: The System for Statistics*. Evanston, IL: SYSTAT, Inc.
- Williamson, Oliver E. (1985), *The Economic Institutions of Capitalism: Firms, Markets, Relational Contracting*. New York: The Free Press.

Reprint No. JMR271102

# CALL FOR PAPERS

The School of Business and Administrative Sciences at California State University, Fresno is pleased to announce the publication of a new refereed professional journal, entitled:

## THE REVIEW OF BUSINESS STUDIES (RBS)

The purpose of the Review is to provide a forum for exchange of ideas among business executives and academicians concerned with business and economic issues. The Review will publish empirical, analytical, review, and survey articles, as well as case studies. Emphasis is placed on instructiveness, clarity, and the direct applicability of the paper to business practices. The Review will solicit high-quality applied-research papers from all disciplines including:

- Accounting • Economics • Finance • General Management
- International Business • Legal Environment of Business
- Management Information Systems • Marketing
- Other Contemporary Business Issues

The Review will publish two issues per year, Spring and Fall. All manuscripts will be reviewed anonymously. Please submit three copies of your manuscript to:

Professor K. C. Chen, Editor  
**The Review of Business Studies**  
 School of Business and Administrative Sciences  
 California State University, Fresno  
 Fresno, CA 93740-0007  
 (209) 294-4964, FAX: (209) 294-4911